

Product Type: r_type

Product name: CDL(F)1-23

Product No.: 1030128

Technical:

Speed for pump data: 2900 rpm

Rated flow: 1 m³/h

Flow range: 0.4~2 m³/h

Rated head: 128 m

Curve tolerance: ISO 9906 Annex A

Materials:

Diffuser\Impeller: 304/316L

CDLPump head\Inlet and outlet chamber: HT200

CDLFSel base\Inlet and outlet chamber: 304/316L

code for rubber: NBR/EPDM

Installation:

Maximum ambient temperature: Max.+40 °C

Connet code: Flange PN25/DN25

Shaft seal: CDLA-12

Liquid:

Liquid temperature: Normal temperature type-15°C ~+70°C ; Hot wanter type-15°C ~+120°C

Electrical: :

Phase: single-phase/Three-phase

Driving motor: 1.1kW

Mains frequency: 50Hz

Protection class: IP55

Insulation class: F

Others: :

Net weight: 33kg



Product Type: r_type

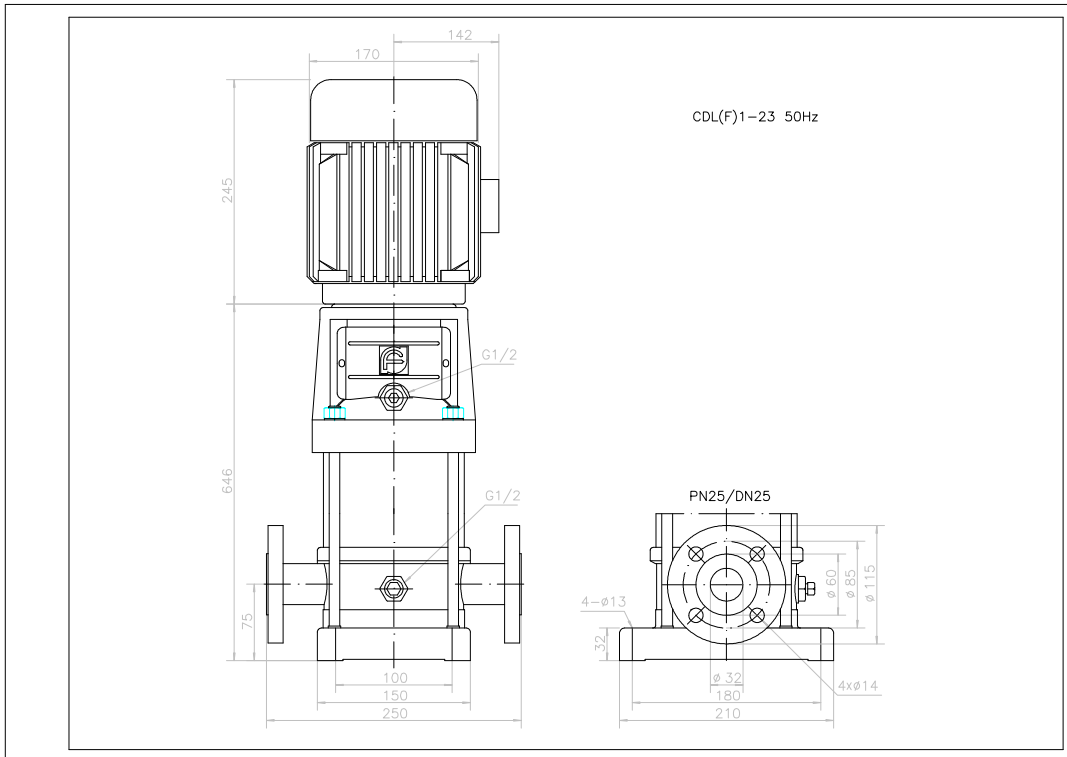
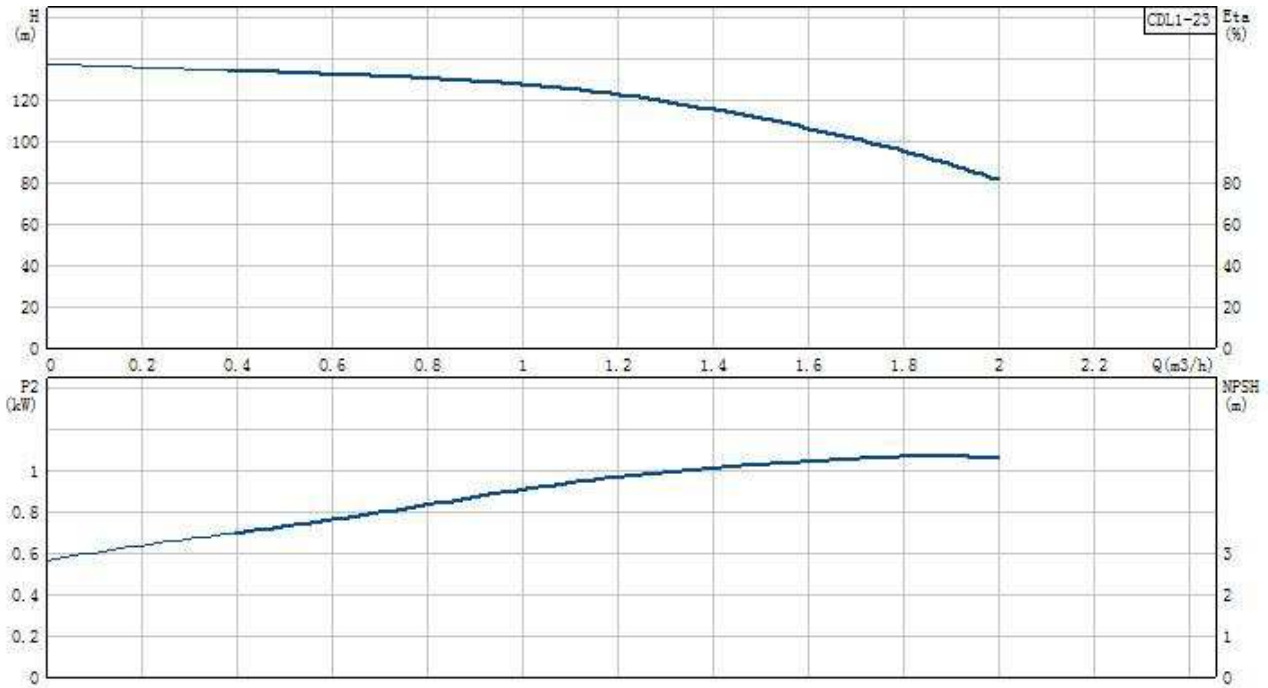

Product Type: r_type

