

**Product Type: r\_type**

Product name: CDL(F)2-26

Product No.: 1030239

**Technical:**

Speed for pump data: 2900 rpm

Rated flow: 2 m<sup>3</sup>/h

Flow range: 1~3.5 m<sup>3</sup>/h

Rated head: 198 m

Curve tolerance: ISO 9906 Annex A

**Materials:**

Diffuser\Impeller: 304/316L

CDLPump head\Inlet and outlet chamber: HT200

CDLFSel base\Inlet and outlet chamber: 304/316L

code for rubber: NBR/EPDM

**Installation:**

Maximum ambient temperature: Max.+40 °C

Connet code: Flange PN25/DN25

Shaft seal: CDLA-12

**Liquid:**

Liquid temperature: Normal temperature type-15°C~+70°C; Hot wanter type-15°C~+120°C

**Electrical: :**

Phase: Three-phase

Driving motor: 3kW

Mains frequency: 50Hz

Protection class: IP55

Insulation class: F

**Others: :**

Net weight: 50kg



**Product Type: r\_type**

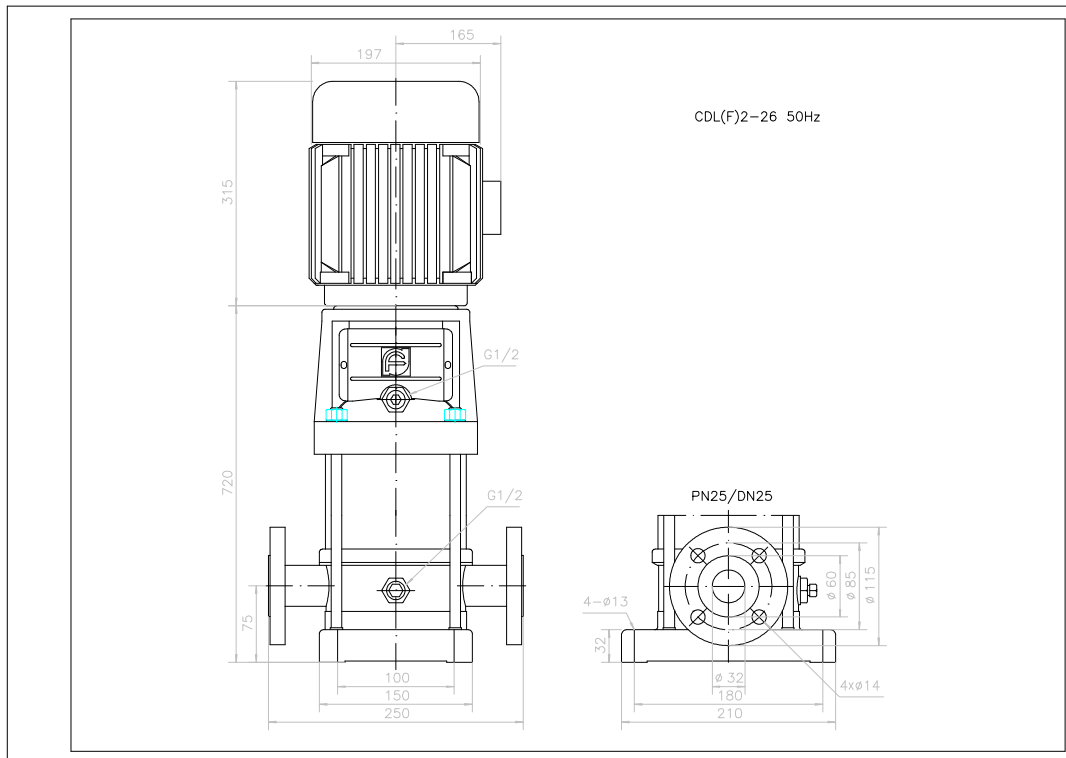
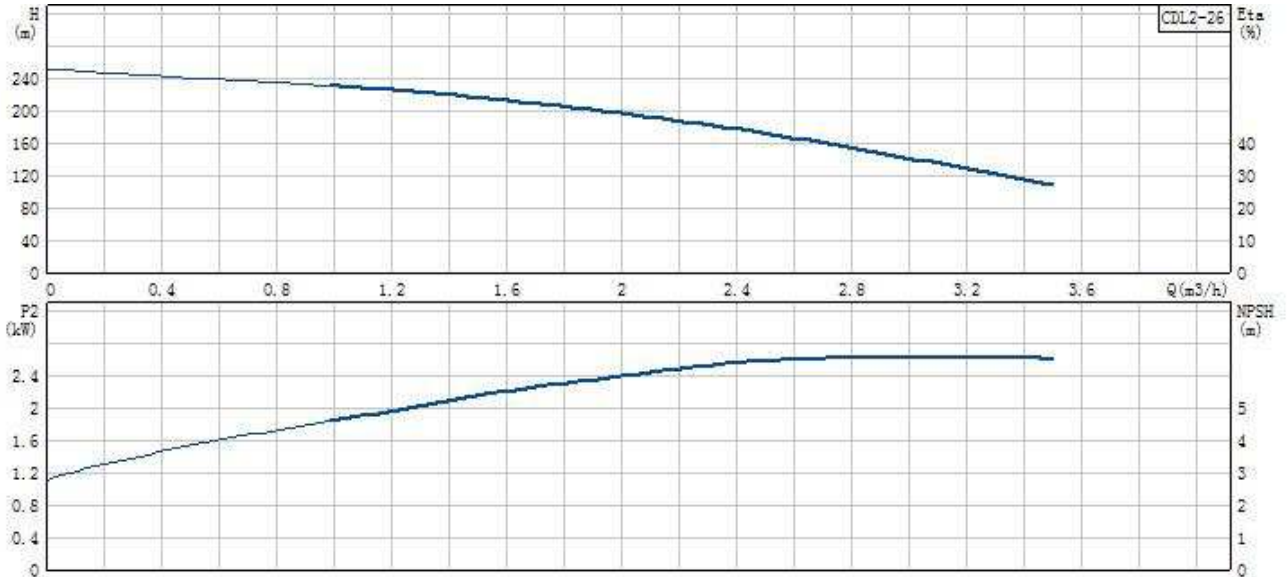

Product Type: r\_type

